

- 1) MAIN DISCONNECT (MOTOR)
- 2) FUSED DISCONNECTS OR CIRCUIT BREAKERS - LOCATED BELOW MAIN DISCONNECT
- 3) ELECTRICAL STUB UP.
- 4) LIGHT SWITCH / G.F.I. OUTLET COMBO - 42" ABOVE F.F.
- 5) 3'-0" x 7'-0" DOOR WITH SELF-CLOSING, SELF-LOCKING FIXTURES.
- 6) TELEPHONE CONNECTION TO CONTROLLER
- 7) CEILING MOUNTED FLUORESCENT LIGHT FIXTURES.
- 8) Optional PTAC UNIT

Issue Date: 7/31/20

PHOENIX
MODULAR ELEVATOR

PHOENIX MODULAR ELEVATOR INC.
4800 PHOENIX DRIVE, MT. VERNON, ILLINOIS 62864
PHONE: (618)-244-2314 FAX: (618)-244-1923
E-mail: Info@phoenixmodularelevator.com
Web page: www.phoenixmodularelevator.com

MODULAR MACHINE ROOM PLAN VIEW			
SIZE	REV	REV. DATE	FILE NO.
A			
SCALE: N.T.S.		DATE: 1/7/16	DWG NO. MMR-SL-1

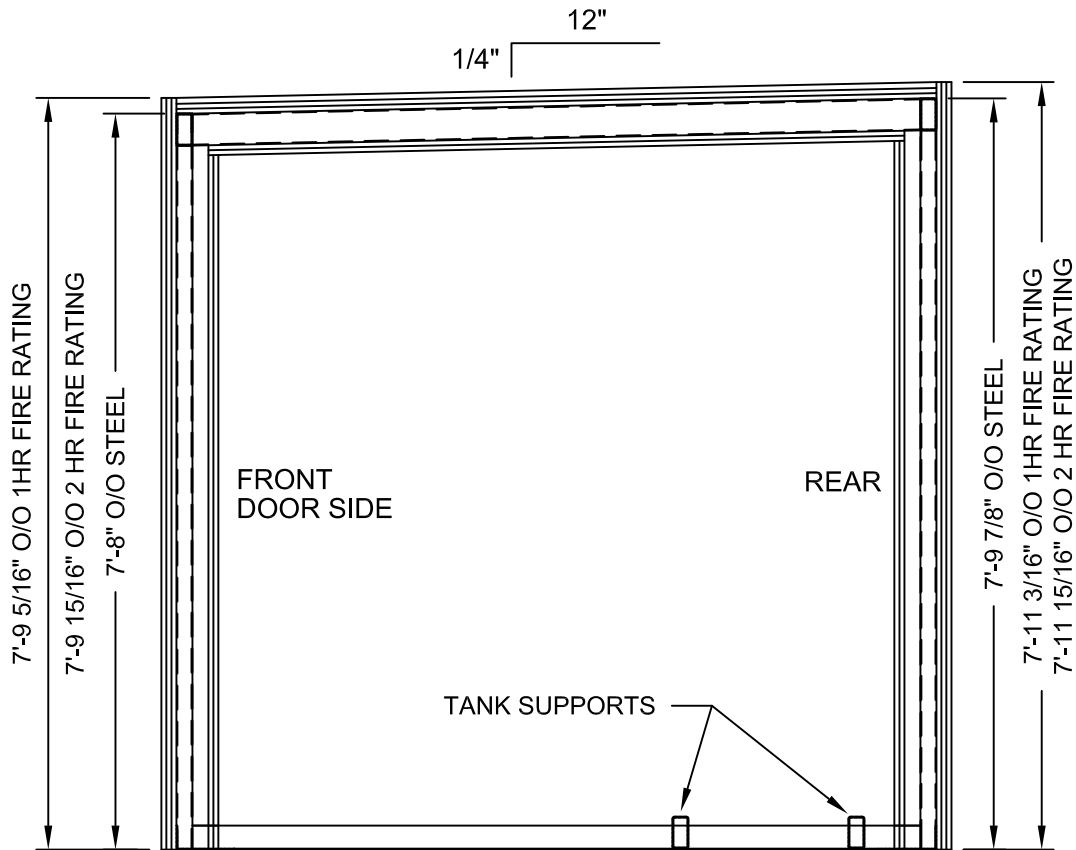

Issue Date: 7/31/20



PHOENIX
MODULAR ELEVATOR

PHOENIX MODULAR ELEVATOR INC.
4800 PHOENIX DRIVE, MT. VERNON, ILLINOIS 62864
PHONE: (618)-244-2314 FAX: (618)-244-1923
E-mail: Info@phoenixmodularelevator.com
Web page: www.phoenixmodularelevator.com

SECTION A - MACHINE ROOM ELEVATION VIEW

SIZE A	REV	REV. DATE	FILE NO.
SCALE: N.T.S.		DATE: 1/7/16	DWG NO. MMR-SL-2

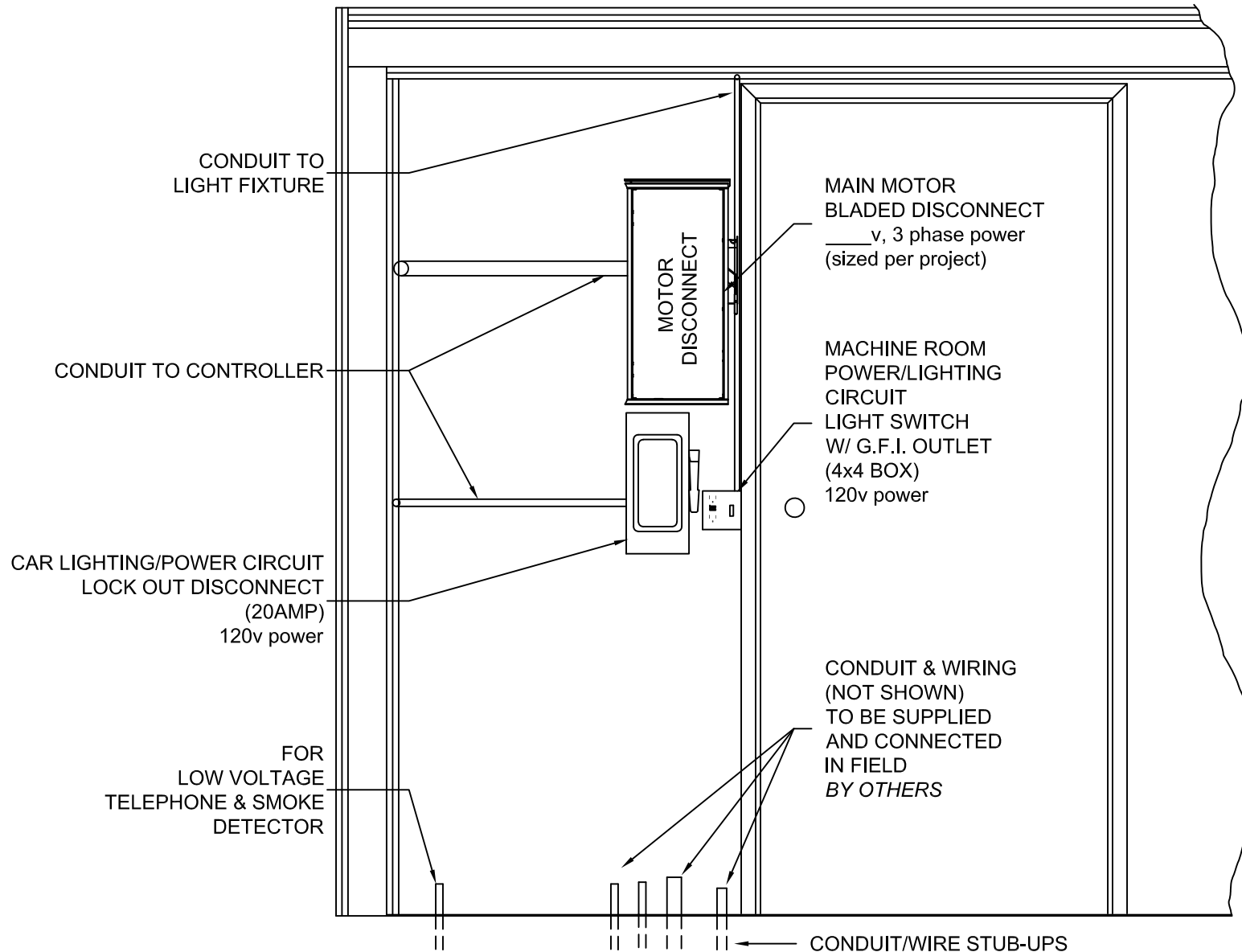

Issue Date: 7/31/20



PHOENIX
MODULAR ELEVATOR

PHOENIX MODULAR ELEVATOR INC.
4800 PHOENIX DRIVE, MT. VERNON, ILLINOIS 62864
PHONE: (618)-244-2314 FAX: (618)-244-1923
E-mail: Info@phoenixmodularelevator.com
Web page: www.phoenixmodularelevator.com

MACHINE ROOM PRE-WIRED LOAD CENTER

SIZE A	REV	REV. DATE	FILE NO.
SCALE: N.T.S.		DATE: 1/7/16	DWG NO. MMR-SL-3

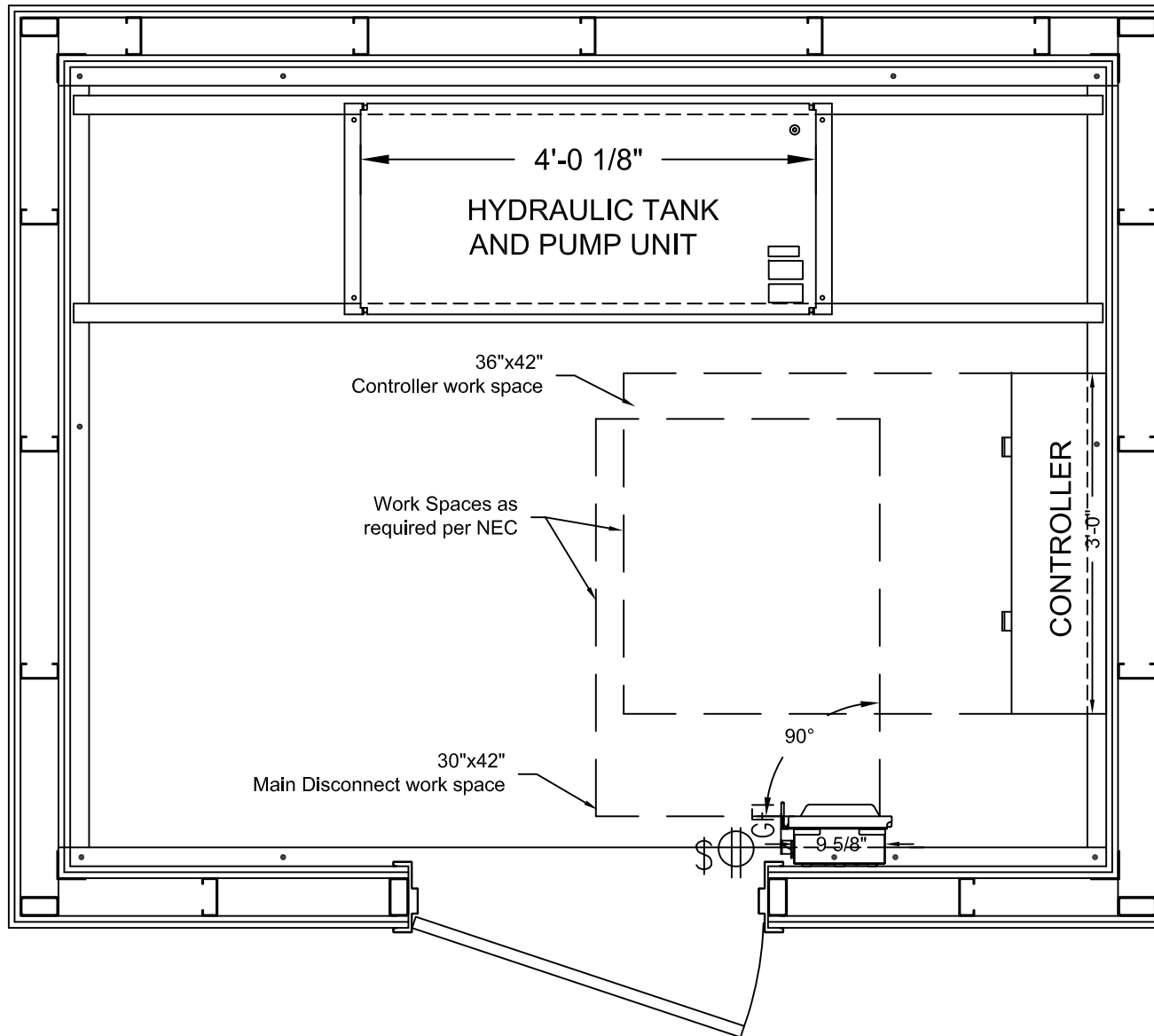

Issue Date: 7/31/20



PHOENIX
MODULAR ELEVATOR

PHOENIX MODULAR ELEVATOR INC.
4800 PHOENIX DRIVE, MT. VERNON, ILLINOIS 62864
PHONE: (618)-244-2314 FAX: (618)-244-1923
E-mail: Info@phoenixmodularelevator.com
Web page: www.phoenixmodularelevator.com

MACHINE ROOM ELECTRICAL SPACES

SIZE A	REV	REV. DATE	FILE NO.
SCALE: N.T.S.		DATE: 1/7/16	DWG NO. MMR-SL-4

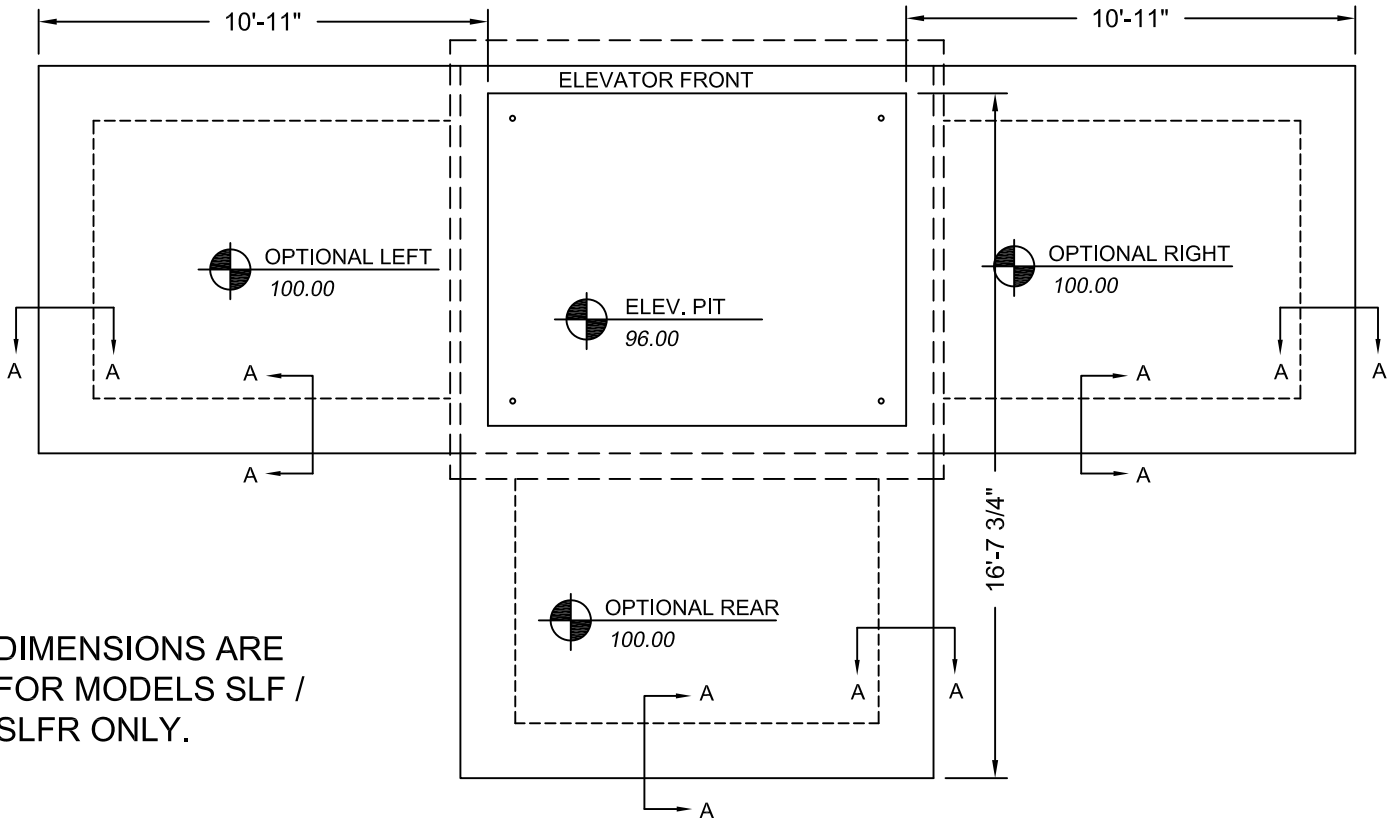

DIMENSIONS ARE FOR MODELS SLF / SLFR ONLY.

PLAN VIEW

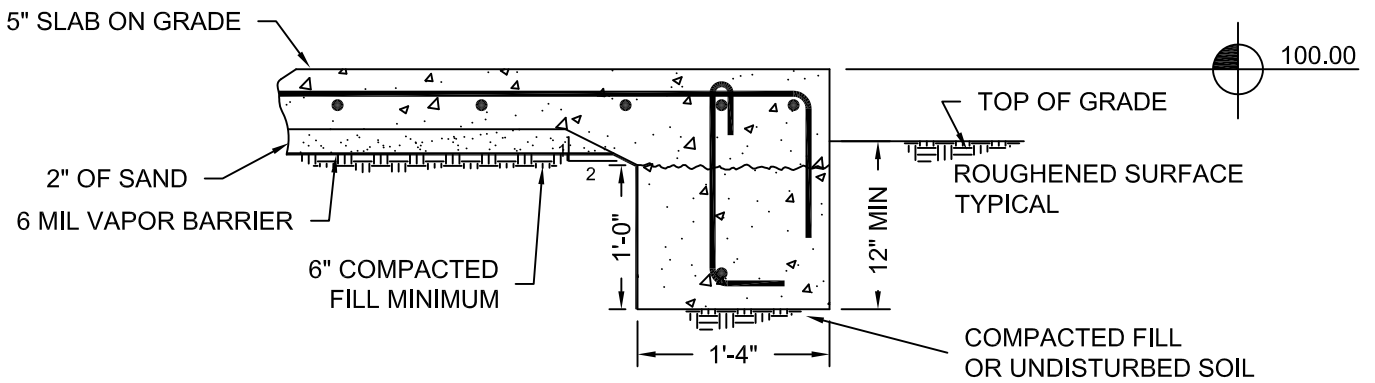

SECTION A-A

Issue Date: 1/7/16



PHOENIX MODULAR ELEVATOR INC.
 4800 PHOENIX DRIVE, MT. VERNON, ILLINOIS 62864
 PHONE: (618)-244-2314 FAX: (618)-244-1923
 E-mail: Info@phoenixmodularelevator.com
 Web page: www.phoenixmodularelevator.com

MODULAR MACHINE ROOM SLAB

SIZE A	REV	REV. DATE	FILE NO.
SCALE: N.T.S.	DATE: 7/31/20		DWG NO. MMR-SL-5