

ALTERNATE METHODS, SUCH AS BELOW, ARE AVAILABLE. ELEVATOR PIT, MACHINE ROOM SLABS, AND ANCHORAGE ENGINEERED BY OTHERS.

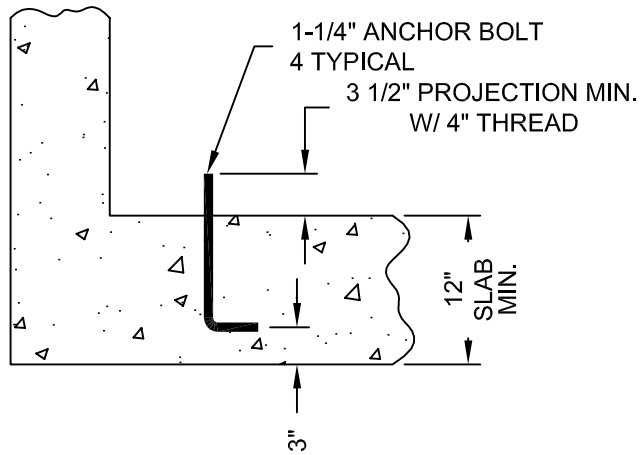

TYPICAL ANCHOR BOLT METHOD ONE

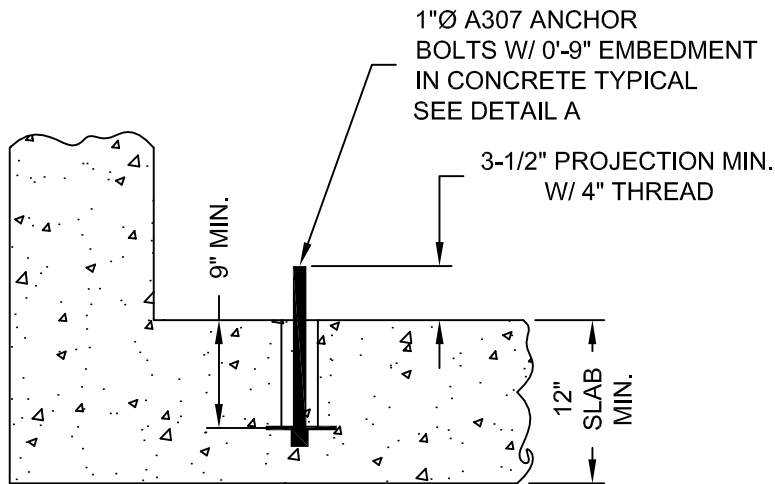

TYPICAL ANCHOR BOLT METHOD TWO

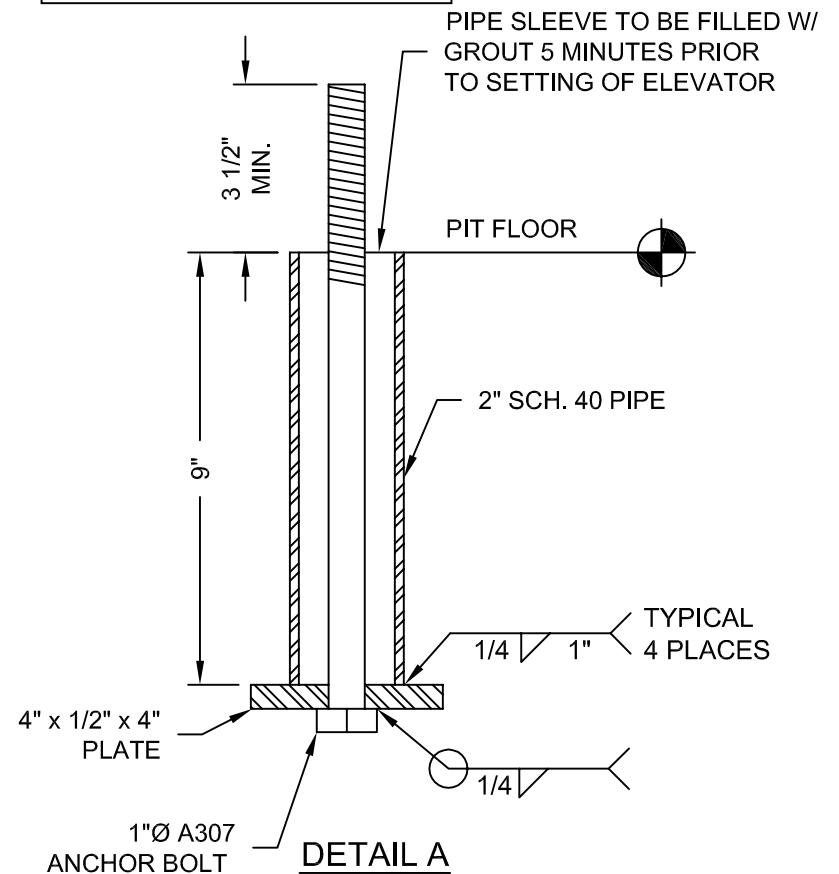
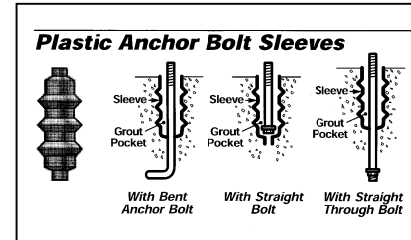

SEE PIT PLANS FOR THE AC3000 AND AC4000 ANCHOR BOLT LOCATIONS.

Issue Date: 6/29/10



PHOENIX MODULAR ELEVATOR INC.
 912 SOUTH 19TH ST. MT. VERNON, ILLINOIS 62864
 PHONE: (618)-244-2314 FAX: (618)-244-1923
 E-mail: info@phoenixmodularelevator.com
 Web page: www.phoenixmodularelevator.com

ELEVATOR HOISTWAY ANCHORAGE DETAIL

SIZE A	REV	REV. DATE	FILE NO.
SCALE: N.T.S		DATE: 07/24/03 T.H.	FP-8